

Model of Vertical Resistivity Distribution of Rock Layers in Jeneberang watershed

***Muh. Altin Massinai , Syamsuddin, Makharani**

Geophysical Studies Program Hasanuddin University
Makassar, Indonesia 90245

*Corresponding author's e-mail: altin_muhammad@yahoo.com

ABSTRACT

Daerah Aliran Sungai (DAS) or Watershed is the accumulation of material from Jeneberang debris avalanche of Mount Bawakaraeng. The Resistivity material from several types of rock settling needs to be identified by using the geoelectric geophysical studies. Geoelectrical resistivity method used in this study aims to map the vertical layers of rock in the upstream and downstream of Jeneberang watershed. The results shows that resistivity values in the upstream of Jeneberang watershed is relatively high at around 300 - 2000 ohmmeter. This price indicates the value of plutonic rock of resistivity type. Around the downstream watershed of Jeneberang, resistivity value is relatively low, ie below 300 ohmmeter. This value indicates that in the downstream of watershed sediment rocks have experienced weathering.

Keywords: avalanches, Jeneberang river, resistivity type, plutonic rocks

I. INTRODUCTION

1. Background

Mount Bawakaraeng and Jeneberang watershed are two phenomena in Gowa district area of South Sulawesi, which has the potential of strategic rock minerals. This is also a disaster that could potentially harm the public. Potential of mineral rock emerges from the avalanche of Mount Bawakaraeng containing plutonic rocks. It can be identified by plotting these rocks vertically .

Geoelectrical resistivity method is categorized as an active method, this is because the artificial source of electric

current is injected into the subsurface through the electrode. The current injected is then measured its responses and the electrical potential of the rocks. With the two variables, the size of each point of apparent resistivity measurement can be identified.

Problems in the management of minerals in an area cannot be separated from the amount of resources and prospects of the layers (stratigraphy) of rock. Broadly speaking, the information available on the existence of minerals in a region is still very limited, both from the amount of reserves and the position and location of the mineral. It is very influential on the investment climate in the region, particularly in mining and mineral resources. Stratigraphy study on

rocks with geoelectrical methods of Schlumberger-Wenner configuration in watershed areas around the valley of Mount Bawakaraeng Jeneberang is expected to make it easier to get distribution and the model of rock position.

This research is expected to give the contribution of ideas and enrich the development of science, especially the mining and mineral resources. It is also expected that this research can give a stratigraphic model of mineral / rock with geoelectric measurement of resistivity type.

Location of the study is the avalanche of caldera wall of Mount Bawakaraeng located in the upper watersheds (*DAS*) and the material of Jeneberang avalanches covering some parts of the river. While Jeneberang watershed is an area draining water that falls over the area to the river flow of Jeneberang. Jeneberang River itself has headwaters around the peak of Mount Bawakaraeng and Lompobattang at an altitude of around 1850 meters above sea level. It flows from the middle of southern Sulawesi island towards the west coast of South Sulawesi, through Bilibili reservoir and empties into the southern city of Makassar. Jeneberang watershed has 60 726 ha, stretching from east to west, between Tallo and Tangka watershed in the north, and Jenelata watershed in the southern part. It is the form of a dendritic pattern of river flow with two branches of the great river of Malino Salo in northern and Kausisi in the southern. Rock formations found in the Jeneberang watershed consists of Lompobattang Formation in the upstream, Camba Formation, Tonasa Formation in the downstream. Lompobattang Formation consists of basalt rocks and volcanic products. While the formation of Camba and Tonasa is dominated by alluvium, breccia and limestone.

2. Electrical Characteristics of Rocks

Rock is a type of material, thus rocks also have the electrical characteristics. A rock will give different responses when a current is injected into the rock. Electric current may derive from the nature itself due to the electric current imbalance or deliberately put into it. In this case, the natural electrical potential of rocks, rock conductivity and dielectric constant of rocks will be investigated.

2.1 Electrical Potential of the rocks.

Electrical Potential of the rocks or natural electric potential natural or self potential due to the electrochemical activity or natural phenomena. Controlling factor of all of this is ground water. This potential is in association with the weathering of sulfide minerals in the body, differences in rock properties (mineral content) on geological contacts, bioelectric activities of organic material corrosion, thermal gradient and pressure gradient. Potential of this nature can be classified into 4 groups, namely electrokinetic potential, diffusion potential, nerust potential and mineralization potential.

1. Electrokinetics Potential. This potential is caused when a solution is moving through a capillary tube or a porous medium.
2. Diffusion potential. This potential occurs when there is a difference of mobility of ions in solution that has different concentration.
3. Nerust Potential. This potential emerges when an electrode is inserted into a homogeneous solution.
4. Mineralization Potential. This potential arises when the two metal electrodes are inserted into the homogeneous solution. This potential value is the largest compared with other potential types. Usually, this potential comes up in the zone containing many sulfides, graphite and magnetic.

While the other types of potential natural causes, such as corrosion, bioelektrik, the temperature gradient and pressure gradient, have been included in one of the groups listed above.

2.2 Investigation of Geoelectrical Resistivity

One of the simplest approaches in the discussion of electrical phenomena in the earth is to assume that the earth is a homogeneous isotropic medium. So that the electric field of source points within the earth are considered to have symmetry ball. Based on Ohm's law, the relationship between electric current density J with the electric field E and the conductivity of the medium σ is filled with,

$$J = \sigma E \quad (2.1)$$

For the electric field E is a conservative field, it can be expressed in terms of V potential gradient as,

$$E = -\nabla V. \quad (2.2)$$

So that the electric current density J can be expressed with,

$$J = -\sigma \nabla V \quad (2.3)$$

If there are no sources of charge accumulated on a regional area, then

$$\begin{aligned} \nabla \cdot J &= \sigma \nabla \cdot E = 0 \\ \text{or } \nabla \sigma \cdot \nabla V + \sigma \nabla^2 V &= 0. \end{aligned} \quad (2.4)$$

For an isotropy homogeneous medium, the conductivity σ is assumed as a constant by the two electrode currents. The electric potential generated from these two sources of these flows is the potential difference measured at two measuring points.

scalar in vector space, so that equation (2.4) becomes,

$$\nabla^2 V = 0 \quad (2.5)$$

Because of the ball symmetry, the potential is only as a function of distance r from the source, then equation (2.5) can be expressed with,

$$\begin{aligned} \frac{\partial V}{\partial r} \left(r^2 \frac{\partial V}{\partial r} \right) &= 0 \\ \text{or } \frac{\partial^2 V}{\partial r^2} + \frac{2}{r} \frac{\partial V}{\partial r} &= 0 \end{aligned} \quad (2.6)$$

Completion of this second order differential equations can be performed through the integration. The solution of the equation satisfied with,

$$V = -\frac{A}{r} + B \quad (2.7)$$

where V is electric potential, A and B respectively are the integration constants with value depends on the boundary condition. At $r = \infty$, the potential at this point is $V = 0$. Based on these boundary conditions, then $B = 0$ and electric potential has a value inversely proportional to the distance from the source.

2.2.1 Electrical Potential by Two Source Flows on Surfaces

If the distance between the two electrode currents are not too large, the potential at any point near the surface will be influenced

In the area near the $C1$ and $C2$ current sources there are drastically potential drastic changes. Meanwhile, near the center point between the two current sources, the potential gradient become smaller and closer to linear. Based on such review, the

measurement of electrical potential is best done at any point between C1 and C2.

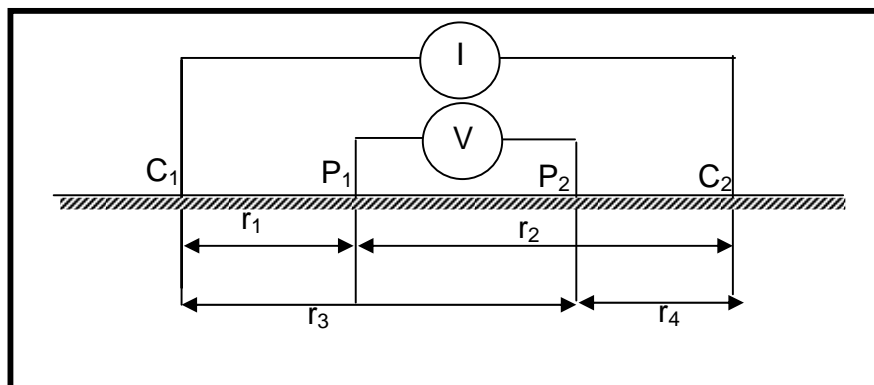

Figure 1. General Form of Electrode Configuration

To determine the electrical potential difference between two potential electrodes (P1 and P2) equation (2.7) can be applied. Potential at a point P1 is caused by the electrode C1,

$$V_{11} = -\frac{A_1}{r_1} \quad (2.7)$$

$$\text{where } A_1 = -\frac{I\rho}{2\pi}. \quad (2.8)$$

While the potential at the point P1 which is caused by the electrode C2 is,

$$V_{12} = -\frac{A_2}{r_2} \quad (2.9)$$

$$\text{in which } A_2 = -\frac{I\rho}{2\pi}. \quad (2.10)$$

Currents on both C1 and C2 electrodes are equal but opposite in direction, so that the total potential at point P1 can be written as,

$$V_{11} + V_{12} = \frac{I\rho}{2\pi} \left(\frac{1}{r_1} - \frac{1}{r_2} \right). \quad (2.11)$$

In the same way the potential at the point P2 obtained, ie;

$$V_{21} + V_{22} = \frac{I\rho}{2\pi} \left(\frac{1}{r_3} - \frac{1}{r_4} \right). \quad (2.12)$$

The potential difference measured between points P1 and P2 are,

$$\Delta V = V(P_1) - V(P_2) = \frac{I\rho}{2\pi} \left[\left(\frac{1}{r_1} - \frac{1}{r_2} \right) - \left(\frac{1}{r_3} - \frac{1}{r_4} \right) \right]. \quad (2.13)$$

While the amount of resistivity,

$$\rho_a = K \frac{\Delta V}{I}. \quad (2.14)$$

with $k = 2\pi \left(\frac{1}{r_1} - \frac{1}{r_2} \right) - \left(\frac{1}{r_3} - \frac{1}{r_4} \right)$ is the configuration factor of measurements in the field.

The formulation of geometrical factor is generally accepted, and reflects the effect of

electrode location where the electrode potential against the current.

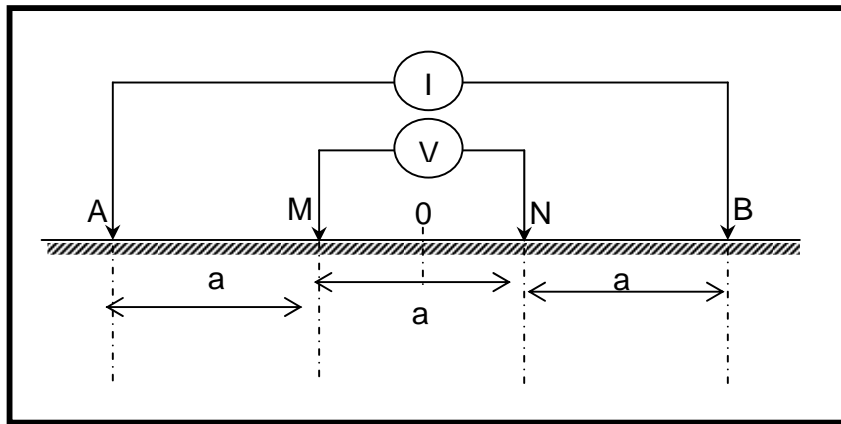

Figure 2. Electroda Array of wenner Configuration

2.3 Electrode Configuration and Configuration Factor

Theoretically, the amount of electrical potential and resistivity by two current point sources at the surface is expressed by using equation (2.13) and (2.14) with the position of r_1 , r_2 , r_3 and r_4 as shown in Figure 1.

In field survey, there are several configuration models that can be used. The differences between models of the form in which the electrode potential and electric current will produce the difference of k geometrical factor. The model configuration used in this study is Wenner Configuration.

This configuration can be used for resistivity mapping or resistivity sounding. Implementation of measurement using Wenner configuration for resistivity mapping and resistivity sounding, distance space between the electrode currents are the same, as shown in Figure 2.

In Wenner configuration, it is known that $AM = MN = BN = a$. Value geometry factor K and the apparent resistivity for this method are:

$$K_W = 2\pi a \quad (2.15)$$

$$\rho_{aW} = 2\pi a \frac{\Delta V}{I} \quad (2.16)$$

II. DESIGN AND RESEARCH METHODS

2.1 Place of Research

The location used as the place for research is in Jeneberang watershed around the valley

west of Mount Bawakaraeng, in Gowa district, with coordinates of $119^{\circ} 34' 42.2''$ - $120^{\circ} 05' 44.7''$ EL and $05^{\circ} 15' 53.6''$ - $05^{\circ} 30' 49.5''$ SL (Figure 3). The processing of field data is performed at the Laboratory of Geophysics, Hasanuddin University.

Measurement of potential difference (Δv) and the large of current (I) is carried out using electrode array according to the Wenner rules in which the expanse of wire is as far as 500 meters from the center point. The direction of expansion is chosen for the flat topography and will not through the hills, river or field prominently different between left and right of center point and should be a straight line. The sequence of measurement is as follows:

1. Create a path and determine the point of observation locations using GPS (Global Positioning System) and mark them with stakes. Stakes that are at the center of measurement are marked S for the guess point of sounding and the measurement is repeated if the **price** of resistivity obtained is conspicuously different. This can happen if the **two currents** and potential electrodes are poorly located or the existence of current leakage.
2. For Shlumberger-Wenner array the value is $K \frac{\pi}{a} ((L/s)^2 - (a/2)^2)$. The K value calculated is based on the position of the electrode. The result of observation and calculation of ρ_s price obtained is plotted on double logarithmic translucent paper. This is done in the field to know the

mistakes made during field measurements.

The field measurement using Geoelectric methods will result in the value of configuration factor, potential difference and current. All data are materials to determine the resistivity values measured for each point of measurement. The value of resistivity measured (apparent) is determined by using the equation for each type of configuration measurement above.

Resistivity pricing could actually be done either manually or komputatif. Manually can be done by curve-fitting method (curve matching). Modeling method with the help of today's computers have been widely used because it is relatively more practical. Computational modeling can be done with the help of software existing today as Resist, Resin52, RES2DIV and RES3DIV. The data measurement will be input for the software and through the determined processing stages, the desired output can be obtained. Output can be in the form of a 1-dimensional, 2 dimensional and even 3-dimensional, depending on the measurement conducted.



Figure 3, Map of Research Sites

III RESULTS AND DISCUSSION

Figure 4 and 5 below show the distribution of rock resistivity as the result of Res2DInv processing software to the value of resistivity measurements in the field. The section of apparent resistivity in pseudosection form is a contour displayed in the form of a certain anomaly color. Here are some apparent resistivity as the result of measurement using Wenner configuration. Field measurement is conducted on sediment avalanches of Mount Bawakaraeng with the track is 50 meters long and spaced 2 meters. Figure 4 shows the resistivity distribution value of rocks on the track which is located in the downstream of Jeneberang watershed. Based on the

trajectory pseudosection section, the track has an apparent resistivity value which is relatively high with 1-2000 Ωm distributed on the surface with $n = 1$ to $n = 3$. The price of resistivity is distributed from east to west at 70-95 meters path length. At position of 12-19 meters with a depth of $n = 3$ (7 meters) resistivity found is $> 1000 \Omega\text{m}$. The price of resistivity is identified as gabbro. These rocks are plutonic igneous rocks. This indicates that the rock is a rock that comes from the avalanche of Mount Bawakaraeng. Mount Bawakaraeng along with Mount Lompobattang is an active volcano in the Tersier era. Those mountains had erupted with melting intrusive eruptions resulting in plutonic rocks such as gabbro, Andesite, Diorite and Granodiorite. The price of

apparent resistivity for $n = 4$ and $n = 5$ has a relatively low resistivity values $<80 \Omega\text{m}$,

which spread from east to west but the layers are increasingly thick to the west.

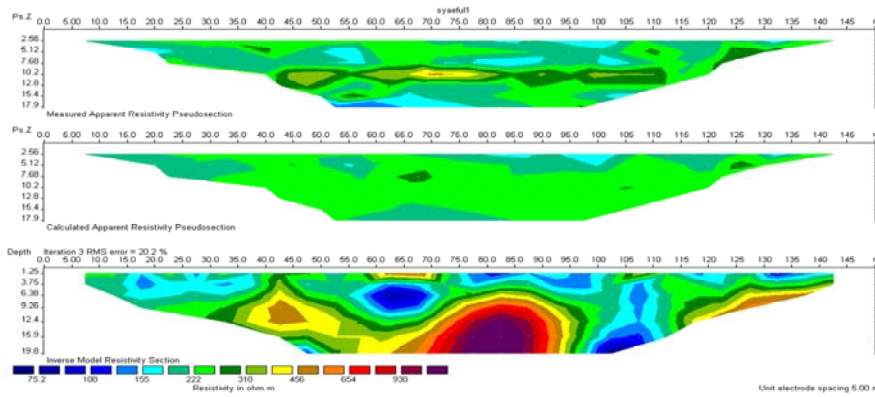

Figure 4. Model rock layer at the location of the downstream of Jeneberang watershed

Figure 5, is the trajectory measurement at the location in the upstream Jeneberang watershed, based on pseudosection section, the price of apparent resistivity is relatively highy with $> 400 \Omega\text{m}$ which spreads from $n = 4$ to $n = 7$ in which to the west the layer is getting smaller. The price resistivity spreads

on the path 2-48 meters long. The price of apparent resistivity is relatively low with $<25.9 \Omega\text{m}$ spreading from $n = 1$ to $n = 4$ from east to west and and the layer is getting thicker to the west.

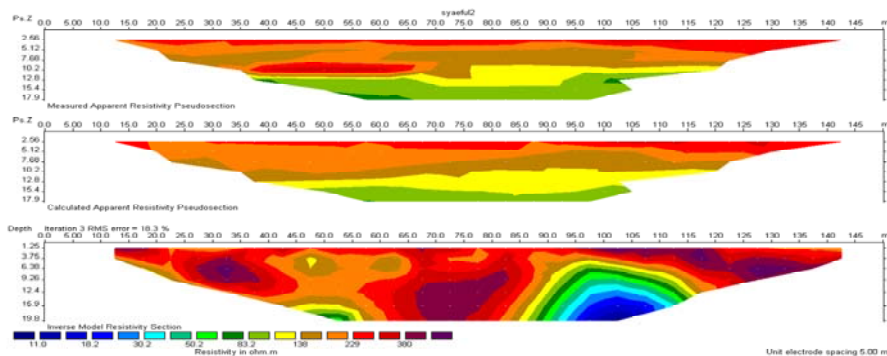















Figure 5. Model of rock layer located at the upstream of Jeneberang watershed

Both tracks are trending from east to west conducted along the Jeneberang watershed. Based on the analysis of pseudosection of high resistivity with $> 300 \Omega\text{m}$ there are 2-46 meters along the trajectory spreading down to $n = 1$ to $n = 4$. The relatively low resistivity of $< 83 \Omega\text{m}$ spreads laterally at a position 14-38 meters, while the downward spreads from $n = 4$ to $n = 8$.

Table 1, shows the results of resistivity distribution at Figure 4 and 5. In the downstream areas, there is a Camba Formation dominated by alluvium, breccias and sand quarter. Plutonic rocks such as gabbro, andesite, is seen in position at a depth above 10 meters. This indicates the rock has been buried by material deposits from avalanches of Mount Bawakaraeng.

Table 1 .Resistivity distribution of rocks layers in Jeneberang watershed

layer code	Resistivity (Ohmmeter)	rocks
	1 - 24	Aluvium
	25 – 30	Clay
	65 – 80	Sandquarter
	250	Breccia
	250 - 300	Andesit

	320 – 420	Granite
	400 - 450	Basalt
	470 - 550	Sandstone
	560 - 640	Limestone
	660 - 790	Granodiorite
	800 - 920	Diorite
	940 - 1500	Conglomerate
	1500 - 2000	Gabbro

While the upstream of Jeneberang watershed is marked on the image with brownish red color of resistivity. This marks the plutonic rocks derived from volcanic eruptions during the Tersier stored in the caldera of Mount Bawakaraeng. These rocks underwent landslides settling around the Jeneberang watershed. Geological map shown in Figure 6 reinforces the interpretation of resistivity of rock strata in the catchment area of Jeneberang.

Limestone in this region has a resistivity of about 560-640 ohm meter. This limestone is accumulated to form Tonasa. Tonasa formation is now used as a raw material of cement factories in Pangkep (Cement Factory Tonasa) and Maros (Bosowa Cement Factory).

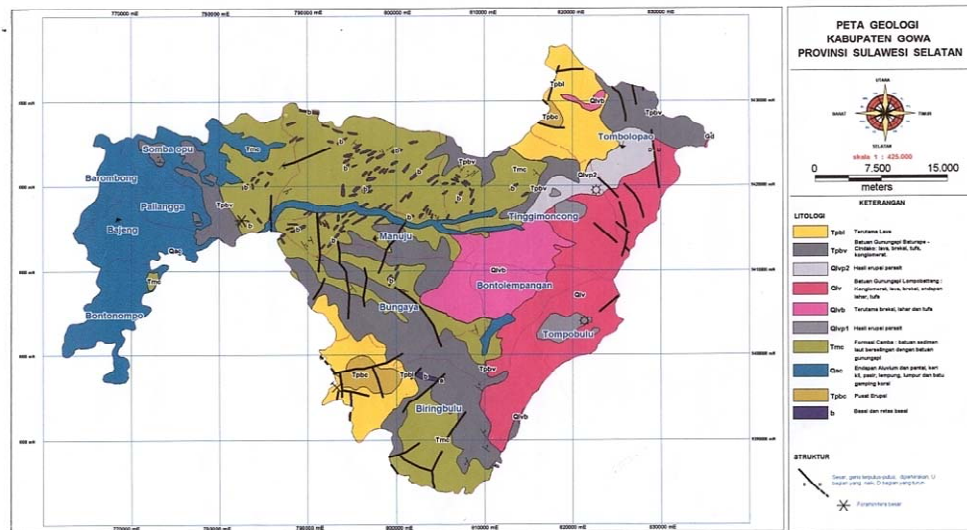

Figure 6 Geological Map of Gowa in South Sulawesi (Sukarno & Supriyatna, 1982)

V. CONCLUSIONS

1. Based on the results of processing with software Res2Dinv, the result shows the distribution model of resistivity distribution is obtained from below the surface. This modeling is a cross-section showing the thickness and width of the layer, represented by the contours of certain colors that have resistivity values in accordance with the results of the calculation. With low resistivity as conductive regions, based on geological data (test pit), this area has rock avalanches originating from Mount Bawakaraeng.

2. Plutonic rocks such as gabbro, andesite, basalt, granite with a resistivity of 300 - 2000 Ohm meter is more dominant in the upstream Jeneberang watershed. While the rocks that have been molding become alluvium, breccia, sand quarter with a resistivity below 300 ohm-meter is more dominant in the downstream Jeneberang

watershed. Rocks in this stream are used as building material.

3. The method of Geoelectrical resistivity of Shlumberger-Wenner configuration can be used as model in detecting the spread of rock layers. This is indicated by color contours and the resistivity of each layer of rock.

REFERENCES

- Akmaluddin. 2006. Pengaruh Fisiografi Dan Curah Hujan Di Bagian Hulu DAS Jeneberang Terhadap Pergerakan Massa Longsoran.. Makassar: State Geophysics Study Program Hasanuddin University
- Barker, R.D. 2001. Principle of Electrical Imaging. University of Birmingham, United Kingdom.
- Bracewell, 2003, Rainfall Triggered Landslides And Debris Flows,

<http://geology.usgs.gov/connections/nps/nps.html>.

Busian, AE, 1983. Electrical conductance in a porous medium, *Geophysics*, 48, pp. 1256-1268,

Dobrin, M.D. and C. H. Savit. 1998. *Geophysical Prospecting*. McGraw-Hill International Editions.

Falah Dervish, et al, 1993, *Penyelidikan Geologi Terpadu Daerah Kabupaten Gowa Propinsi Sulawesi Selatan*, Department of Mines and Energy of South Sulawesi, Makassar.

Giani, G.P, 2002. *Rock Slope Stability*. A. A. Balkema. Rotterdam.

Hendrajaya, L. and Arif, I., 2002, *Geolistrik Tahanan Jenis*. Monograph Methods of Exploration, Earth Physics Laboratory, ITB, Bandung.

Loke, M.H. 2004. *Electrical imaging surveys for environmental and engineering studies. A practical guide to 2-D and 3-D surveys*, Penang, Malaysia,

Parasnis, D.S., 1997. *Mining Geophysics*, Elsevier Publ. Co., Amsterdam

Parasnis, DS, 1997, *Principles of Applied Geophysics*. Chapman & Hall, 5th edition, Reynolds, John. 1997. *An Introduction to Applied and Environmental Geophysics*. John Weley and Sons Ltd.. England

Stroub, A, 1995. General formulation of the electric stratified equation, *Geophysics*, 60, pp. 1656-1667

Sumadi Darmawan, 2001. *Pengukuran Tahanan Jenis*, Handbook of Measurement

of geoelectric Mine, Mine Department, ITB-Bandung

Sukamto, Rab and Supriatna. 1982. *Geologi Lembar Ujungpandang, Benteng dan Sinjai Bandung: Geological Research and Development Center*

Syamsuddin. 2007. *Penentuan Bidang Gelincir Longsoran dengan Menggunakan Metoda Resistivitas*. Makassar: *Journal Fusi*. V.10, no.2.

Telford, W.M., 1982. *Applied Geophysics*, Cambridge University Press,